



What is the Soul of the city?

Cityscape is created by architecture and city planning, mixed together with nature. Every city has a unique cityscape, that allows us to experience cities in their own way. Our experience is represented by our activities and in the way we sense our surroundings – how we sense the unique space of every city. And this unique perceptible Space is the Soul of the City.

Concept

„Tourist“ allows to visit the Baltic capitals with live streaming. The idea is to let everybody experience the Soul of the city for themselves, by seeing, hearing and moving around in Tallinn, Riga and Vilnius.

PAVILION DRAWINGS

3 sides system panel
top view / scale 1:50

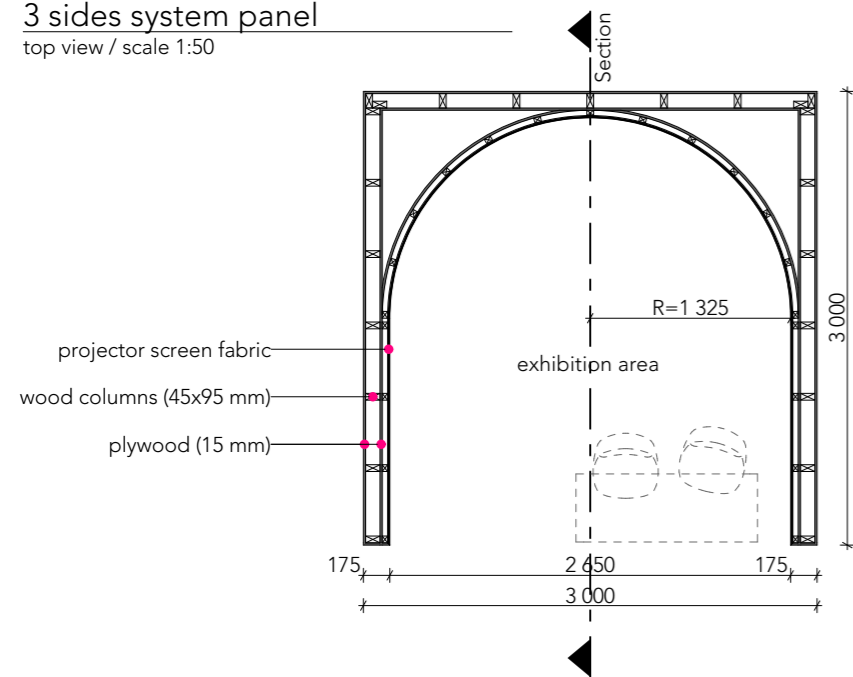

2 sides system panel
top view / scale 1:50

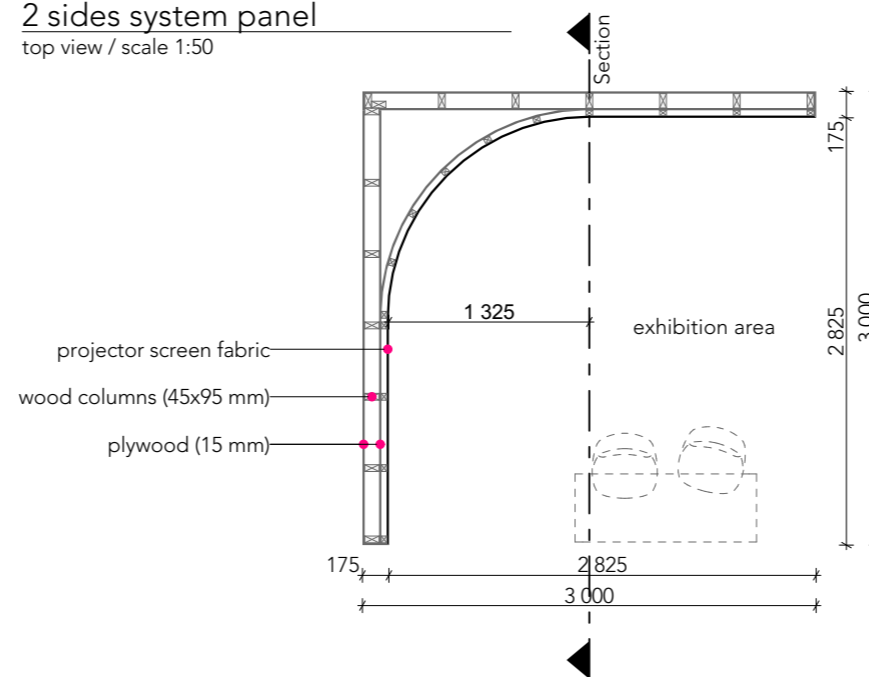

Section
scale 1:50

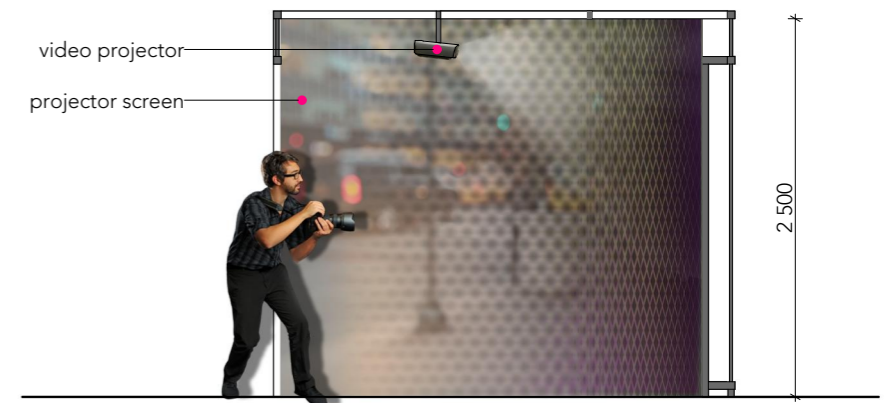

How it works?

A 360° outdoor camera will be installed in the three capitals. The visitor has earphones for hearing the city and a remote control for turning around and switching between cities. A curved shape wall is installed in the booth and a video projector shows the live image onto the wall.

How it's made?

The curved wall is made out of wooden columns, covered with plywood and finished with projector screen fabrics.



Souvenir

Tourists can take a photo or a selfie for keeping the memories of visiting the Baltics.

